

3-5111 / 3-5161



■ The Company

Production, R+D+i, evolution.



VALVULAS NACIONAL, S.A. was established in Spain in 1976. The main target was to assist the petrochemical and chemical industries emerging in Spain at that time. Right from the start VALVULAS NACIONAL, S.A., has been designing and producing safety valves according to most recognized international standards and norms: API, ASME, ASTM and the European directives 97/23 & 94/9 CE. Our production process is accredited by an ISO 9001-2008 certification.



Our know how and capacity to adapt to the constantly changing demands of the market, made possible the introduction of new products designed for new applications on the market, like THERMOSOLAR PLANTS, where VALVULAS NACIONAL has supplied safety valves to more than 16 complete plants all over the world, while at the same time continuously supplying to all main players of the Spanish petrochemical, chemical and refining industries.

Production capacity.

VALVULAS NACIONAL, S.A. valves' have their discharge coefficients approved in laboratory tests, in order to guarantee and assure that correct values are being used for every sizing process.

In our Technical sales department we count with a modern software which allows us to verify all the possibilities, and to assure strict fulfillment of all international standards.

VALVULAS NACIONAL, S.A. has established representation agreements with the most important O.E.M. companies in the safety sector of the industry, consolidating us as one of the main companies by product range; design and consulting in new plants or in new process.

Our continuous growth, shows a clear trend, which confirms the integration of our workers to provide first class service to our customers and partners.





Factory & location.

Our facilities in Rubí (Barcelona - Spain), with more than 1.200 m2 are fully prepared for our production activities: machining with modern CNC, assembling and testing. We also have long term agreements with approved workshops, which provides us with flexibility and fast feedback to customers demands, with full quality guarantee which has always been our main target.



Strategic alliances.

Nowadays VALVULAS NACIONAL, S.A. starts an internationalization process, establishing representation agreements in different countries and continents all over the world, with specialized companies that will provide added value in our service towards the end user.
VALVULAS NACIONAL providing safety since 1976 !



■ Index

• GENERAL FEATURES	5
• PART LIST	6
• OPERATING CHARACTERISTICS TABLE	6
• BILL OF MATERIALS	7
• ACCESSORIES AND CONNECTIONS	8
• GENERAL DIMENSIONS 3-5111	9
• GENERAL DIMENSIONS 3-5161	10
• CORRECTION COEFFICIENTS CHARTS	11
• AIR DISCHARGE FLOW	12
• STEAM DISCHARGE FLOW	13
• LIQUIDS DISCHARGE FLOW	14
• DEFINITIONS (EN ISO 4126-1)	15

■ General features

Safety and Relief Valve 3-5111

3-5111 NACIONAL series is an angular type safety relief valve at 90° between the inlet and outlet connections, with treaded or flanged connections, full nozzle, direct action and spring loaded, with full lift and fast opening.

Design

- Valve body is angular type at 90° between inlet and outlet. In the flanged version, these are integrals from casting (not welded). The smooth section changes help reducing turbulences; therefore, fluid evacuation on discharge is improved.
- Full nozzle type, guided and screw to body, enabling perfect alignment and easy disassembling.
- Disc is separate from disc holder, for that reason its repair or change is improved and a better selection of materials can be performed.
- Guide has a large disc holder guide area to prevent premature damage, ensuring perfect alignment with all internals.
- Bellows are performed so its average area is equal to orifice area thus achieving perfect valve balance and consequently perfect operation before variable back pressures. Its meticulous design enables maximum pressures and temperatures to be supported achieving a high degree of elasticity.
- Springs are designed with experimental highly reliable calculation software and manufactured with the ideal material qualities for the process conditions, ensuring elasticity and accurate repetition of valve opening.

Used interchangeably as safety or relief valves, for both gases and liquids. It's typically used as thermal expansion valve and also used for discharge of small flows.

Upon request are also available options as lifting lever, "test-gag", "O-Ring", heat jacket, opening sensor etc.

Safety and Relief Valve 3-5161

The model 3-5161, is created from the basic design model 3-5111, but differs by having bellows compensation, which allows absolute precision in the calibration independently of the backpressure, in addition to the protection of internal parts for return of corrosive gases by the discharge pipelines.

CODES AND STANDARDS

Valves have been designed and manufactured in compliance with the following directives, codes and standards:

European Directive:	97/23/CE (PED)
European Directive:	97/9/CE (ATEX)
Design:	EN ISO 4126-1 / ASME VIII DIV.1
Certifications:	PED MODULO B+D
Pressure and Temperature Limits:	API-526 y ASME B16.34
Tests:	API-527 y ASME B16.34
Quality System:	EN ISO 9001:2008
Materials:	ASME/ASTM y EN

SIZES AND RATINGS

Standard sizes and ratings:

ASME:	
Sizes:	½"x¾" to 1"x1"
Rating:	150# to 2500#
EN/ISO:	
Sizes:	DN-15xDN-25 to DN-25xDN-25
Rating:	PN-10 to PN-250



The safety valve is an automatic direct action accessory whose function is to relieve excessive overpressures in the recipients and installations that protects. Its main characteristics, allowing is its sudden fluid discharge with complete and fast opening (pop).

Automatic valve opening is produced because of the additional push provided by the overpressure of the fluid itself helping to overcome spring resistance. Once the installation has recovered its normal service condition, the valve closes again.

The data contained in this catalogue are indicative. Válvulas Nacional, S. A., reserves the right to change this catalogue without notice. Always check the specification sheets.

■ **Part list**

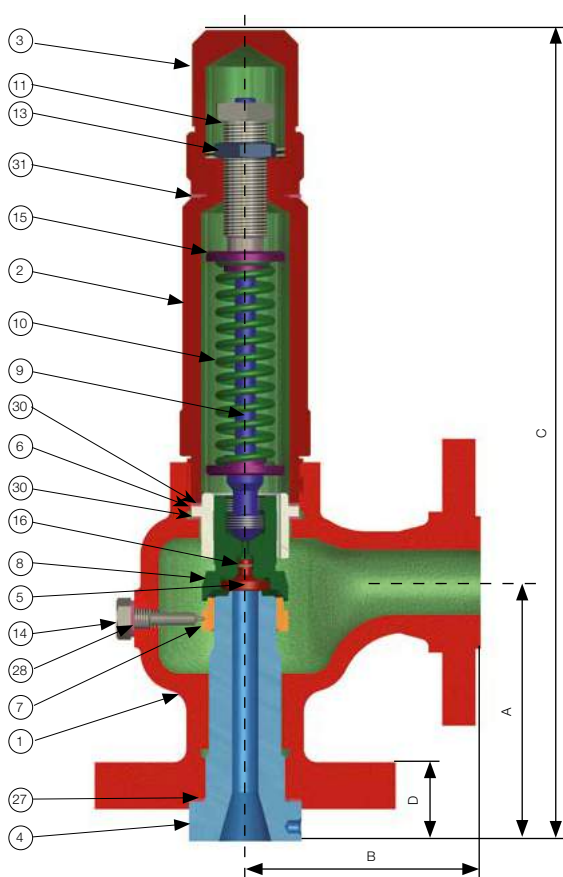

CONVENTIONAL

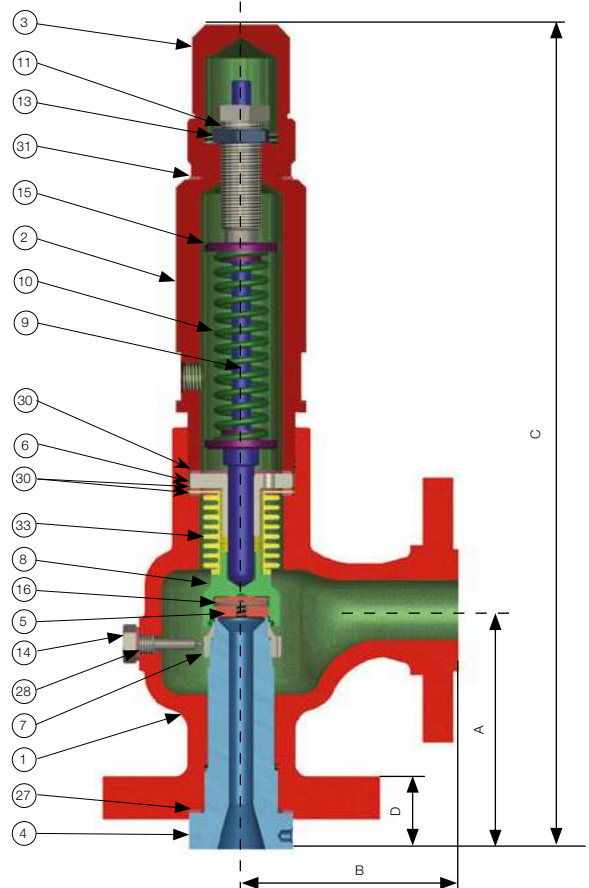

BELLOWS VALVE

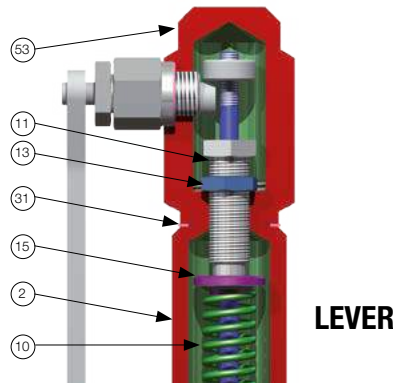

LEVER

Operating technical characteristics table

SAFETY VALVE MODEL 3-51			3-5111	3-5161	3-5111	3-5161
			Conventional	Bellows	Conventional	Bellows
SERVICE			GAS		LIQUID	
DISCHARGE COEFFICIENT (at 10% of overpressure)	(1)	KD	0,94		0,80	
BLOWDOWN		MAX.	10% (2)		15% (3)	
		MIN.	-2%		-2,5%	
SET PRESSURE TOLERANCE	(4)	±	3%			
MINIMUM SET PRESSURE	ASME VIII Div.1 (bar)		1			
	EN ISO 4126-1 (bar)		0,5			

(1) or 0,1 bar, whichever is greater - (2) or 0,3 bar, whichever is greater - (3) or 0,6 bar, whichever is greater - (4) or 0,6 bar, whichever is greater

■ Bill of materials

CLASS		A	B	C	D	E	N1 (Duplex)	O (Super Dup.)	NACE - A
ITEM	DENOMINATION	-29 a 232 °C	233 a 425 °C	426 a 538 °C	-46 a 345 °C	-268 a 538 °C (*)	-29 a 260 °C	-29 a 316 °C	-29 a 425 °C
1	BODY	SA 216 WCB	SA 216 WCB	SA 217 WC6	SA 352 LCB	SA 351 CF8M	SA 995 CD4MCuN (3)	SA 995 CD3MWCuN (3)	SA 216 WCB
2	BONNET	SA 105	SA 105	SA 479 316	SA 479 316	SA 479 316	SA 479 S32550	SA 479 S32760	SA 105
3	CAP	SA 105	SA 105	SA 479 316	SA 479 316	SA 479 316	SA 479 316	SA 479 316	SA 105
4	NOZZLE	SEE SUBCLASS							
5	DISC								
6	GUIDE	A 479 316	A 479 316	A 479 316	A 479 316	A 479 316	A 479 S32550	A 479 S32760	A 479 316
7	ADJUSTING RING	A 479 316	A 479 316	A 479 316	A 479 316	A 479 316	A 479 S32550	A 479 S32760	A 479 316
8	DISC HOLDER	A 479 410	A 479 410	A 479 410	A 479 410	A 479 316	A 479 S32550	A 479 S32760	A 479 316
9	STEM	A 276 420 (8)	A 276 420 (8)	A 276 420 (8)	A 276 420 (8)	A 479 316	A 479 316	A 479 316	A 479 316
10	SPRING	A.C. 50CRV4	Inconel X-750	Inconel X-750	A 313 316 (4)	A 313 316 (4)	A 313 316 (4)	A 313 316 (4)	INCONEL X-750
11	ADJUSTING SCREW	A 582 303	A 582 303	A 582 303	A 582 303	A 582 303	A 582 303	A 582 303	A 582 303
13	NUT	A 582 303	A 582 303	A 582 303	A 582 303	A 582 303	A 582 303	A 582 303	A 582 303
14	LOCK SCREW	A 582 303	A 582 303	A 582 303	A 582 303	A 582 303	A 582 303	A 582 303	A 582 303
15	SPRING BUTTON	F-212	F-212	F-212	A 582 303	A 582 303	A 582 303	A 582 303	F-212
16	ELASTIC RING	AISI 302	AISI 302	AISI 302	AISI 302	AISI 302	AISI 302	AISI 302	AISI 302
17	ELASTIC PIN	AISI 302	AISI 302	AISI 302	AISI 302	AISI 302	AISI 302	AISI 302	AISI 302
27	GASKET	Compressed Fibers	GRAPHITE/AISI 316			Compressed Fibers (1)(2)			Comp. Fibers (1)
28	GASKET	Compressed Fibers	GRAPHITE/AISI 316			Compressed Fibers (1)(2)			Fibras Prens.(1)
30	GASKET	Compressed Fibers	GRAFITO/AISI 316			Compressed Fibers (1)(2)			Comp. Fibers (1)
31	GASKET	Compressed Fibers	GRAPHITE/AISI 316			Compressed Fibers (1)(2)			Comp. Fibers (1)
33	BELLOWS	AISI 316Ti (5)	AISI 316Ti (5)	AISI 316Ti (5)(6)	AISI 316Ti (5)	AISI 316Ti (5)(6)	AISI 316Ti (5)	AISI 316Ti (5)	INCONEL 625
34	GASKET	COMPRESSED FIBERS (1)							
43	BRACKET	A 105	A 105	A 105	A 105	A 479 316	A 479 316	A 479 316	A 105
44	SET BOLT	AISI 304	AISI 304	AISI 304	AISI 304	AISI 304	AISI 304	AISI 304	AISI 304
45	PLAIN LEVER STEM	A 479 316	A 479 316	A 479 316	A 479 316	A 479 316	A 479 316	A 479 316	A 479 316
46	SPLIT PIN	AISI 304	AISI 304	AISI 304	AISI 304	AISI 304	AISI 304	AISI 304	AISI 304
47	PLAIN LEVER	A 351 CF8M	A 351 CF8M	A 351 CF8M	A 351 CF8M	A 351 CF8M	A 351 CF8M	A 351 CF8M	A 351 CF8M
53	LAVER CAP	SA 105	SA 105	SA 479 316	SA 479 316	SA 479 316	SA 479 316	SA 479 316	SA 479 316
54	LEVER STEM	A 479 316	A 479 316	A 479 316	A 479 316	A 479 316	A 479 316	A 479 316	A 479 316
56	LEVER SHAFT	A 479 316	A 479 316	A 479 316	A 479 316	A 479 316	A479 316	A479 316	A 479 316
57	PACKING	BRAID GRAPHITE							
58	PACING NUT	A 105	A 105	A 479 316	A 479 316	A 479 316	A 479 316	A 479 316	A 479 316
59	PACKED LEVER	A.C.	A.C.	A.C.	A.C.	A.C.	A.C.	A.C.	A.C.
62	SHAFT BRACKET	A 105	A 105	A 479 316	A 479 316	A 479 316	A 479 316	A 479 316	A 479 316
63	ELASTIC RING	AISI 302	AISI 302	AISI 302	AISI 302	AISI 302	AISI 302	AISI 302	AISI 302
64	GASKET	COMPRESSED FIBERS							
65	SPIRAL PIN	AISI 304	AISI 304	AISI 304	AISI 304	AISI 304	AISI 304	AISI 304	AISI 304
67	TEST GAG	A.C.	A.C.	A.C.	A.C.	AISI 304	AISI 304	AISI 304	A.C.

(*) At temperatures above 538°C, use only when the carbon content of CF8M and 316 is 0,04% or higher

SUBCLASS		1	2	3	4	10 (Duplex)	11 (Super Dup.)
4	NOZZLE	SA 479 316	SA 479 316 + ST	SA 479 316+ST.	SA 479 316	SA 479 S32550	SA 479 S32760
5	DISC	SA 479 316	SA 479 316 (7)	SA 479 316+ST.	SA 564 630 (7)	SA 479 S32550	SA 479 S32760

(1) T>232°C Graphite material

(2) T<-29°C Graphite material

(3) Optional: Made of equivalent bar material

(4) T>300°C Inconel X-750 material (tempered)

(5) Endings made of S.S. 316L

(6) T>450°C Inconel 625 material

(7) H900 Condition, hardness between 40 ÷ 47 HRC. For temperatures > -30°C.H1150-M Condition, hardness between 27 ÷ 30 HRC. For temperatures < -30°C.

(8) Tempered and annealed a 45 ÷ 50 HRc



■ Accessories

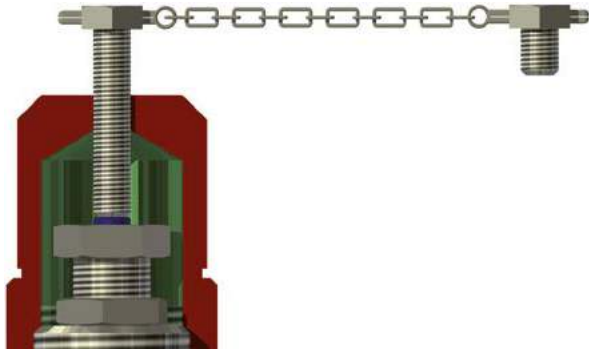

TEST-GAG

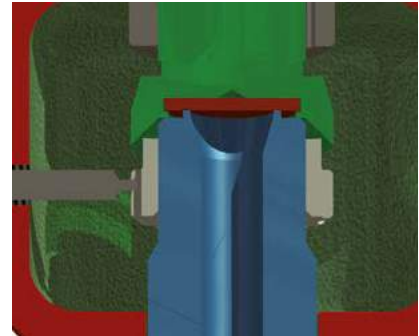

O-RING



HEATING JACKET

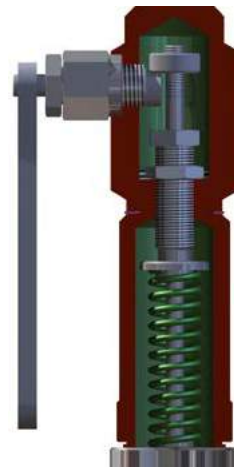

LEVER

■ Connections

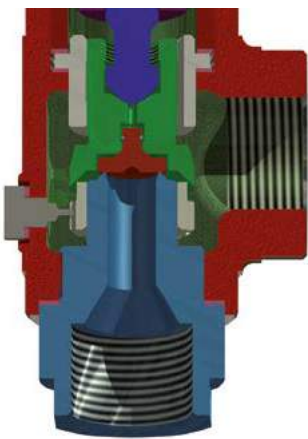

THREADED FEMALE

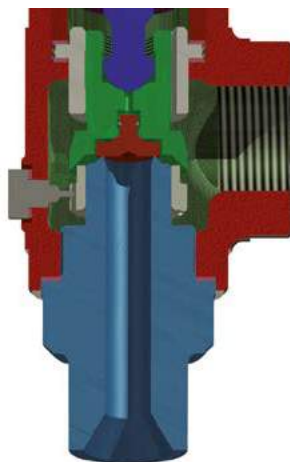

THREADED MALE

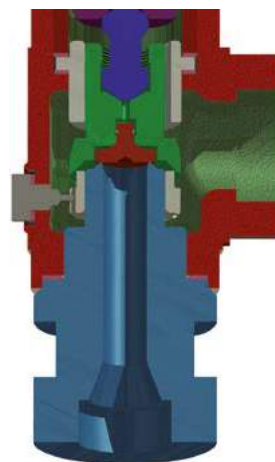

SOCKET WELDING

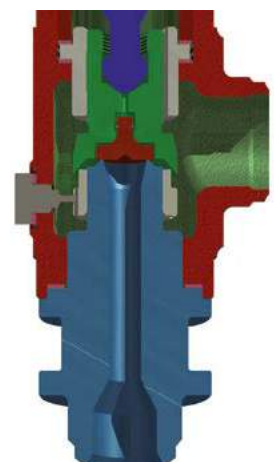

BUTT WELDING

■ General Dimensions

		SIZES				ORIFICES	MODEL 3-5111									
		INLET	OUTLET		General Dimensions (mm)					Std.	Level					
					A		B	C	D	E	Weight - (Kg)					
FLANGED CONNECTIONS	DIN	"INLET PN-16÷160 OUTLET PN-16÷40"	DN-15	DN-25		C, D, E	99	90	311	30	339	6	7			
			DN-20			C, D, E, F										
			DN-25			C, D, E, F										
	ASME	"INLET 150÷600# OUTLET 150#"	1/2"	1"		C, D, E										
			3/4"			C, D, E, F										
			1"			C, D, E, F										
		"INLET 900/1500# OUTLET 150/300#"	1/2"	1"		C, D, E	105	317	36	345	7	8				
	3/4"		C, D, E, F													
	1"		C, D, E, F													
	"INLET 2500# OUTLET 300#"	1/2"	1"		C, D, E	111	323	44	351	8	9					
THREADED CONNECTIONS	NPT/GAS	H/H	1/2"	3/4"	1"	1 1/4"	C, D	46	265	293	309	3	4			
			3/4"	C, D, E, F												
			1"	C, D, E, F												
	NPT/GAS	M/H	1/2"	3/4"	1"	1 1/4"	C, D							90	300	328
			3/4"	C, D, E, F												
			1"	C, D, E, F												

ORIFICES	TIPO	Ø mm.	cm ²	Set Pressure Range
	C	6,3	0,31	0,5÷420 (barg)
	D	10	0,78	0,5÷180 (barg)
	E	12,7	1,26	0,5÷100 (barg)
	F	15,9	1,98	0,5÷55 (barg)

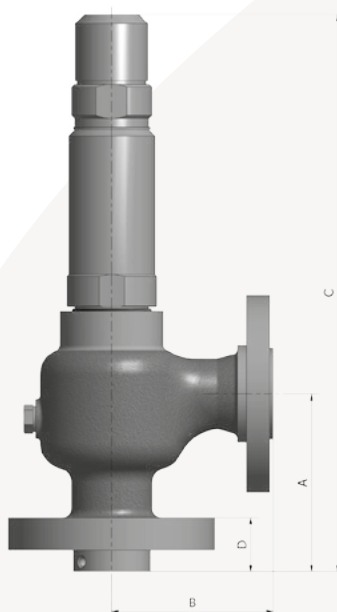

FLANGED



**THREADED
FEMALE
NOZZLE**

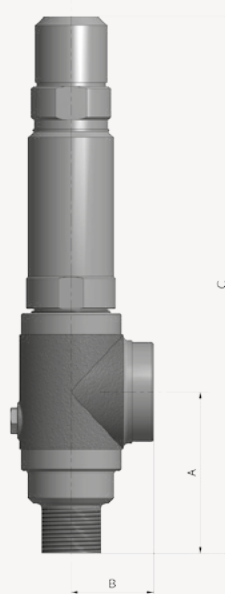

**THREADED
MALE
NOZZLE**

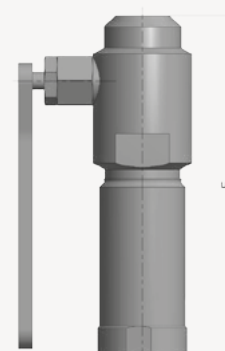

LEVER



■ **General dimensions**

						MODEL 3-5161										
		SIZES				ORIFICES	General Dimensions (mm)					Std.	Level			
		INLET	INLET				A	B	C	D	E	Weight- (Kg)				
FLANGED CONNECTIONS	DIN	"INLET PN-16÷160 OUTLET PN-16÷40"	DN-15	DN-25			C, D, E	99	341	30	369	7	8			
		DN-20														
		DN-25														
	ASME	"INLET 150-600# OUTLET 150#"	1/2"	1"			C, D, E									
		3/4"	C, D, E, F													
		1"	C, D, E, F													
ASME	"INLET 900/1500# OUTLET 150/300#"	1/2"	1"			C, D, E	105	347	36	375	8	9				
	3/4"	C, D, E, F														
	1"	C, D, E, F														
ASME	"INLET 2500# OUTLET 300#"	1/2"	1"			C, D, E	111	353	44	381	9	10				
	3/4"	C, D, E, F														
	1"	C, D, E, F														
THREADED CONNECTIONS	NPT/GAS	H/H	1/2"	3/4"	1"	1 1/4"	C, D	46	295	311	323	4	5			
			3/4"	C, D, E, F												
			1"	C, D, E, F												
	NPT/GAS	M/H	1/2"	3/4"	1"	1 1/4"	C, D							90	330	358
			3/4"	C, D, E, F												
			1"	C, D, E, F												

ORIFICES	TYPE	Ø mm.	cm ²	Set Pressure Range
	C	6,3	0,31	0,5 ÷ 55 (barg)
	D	10	0,78	
	E	12,7	1,26	
	F	15,9	1,98	

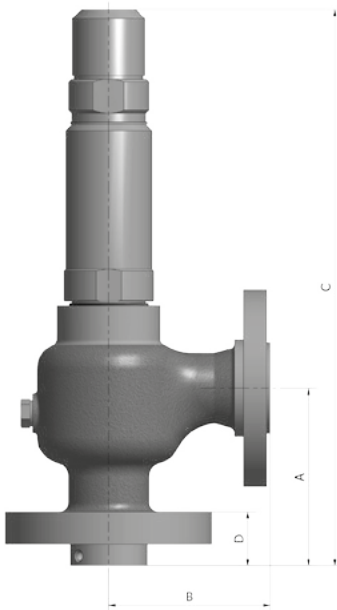

FLANGED



**THREADED
FEMALE**

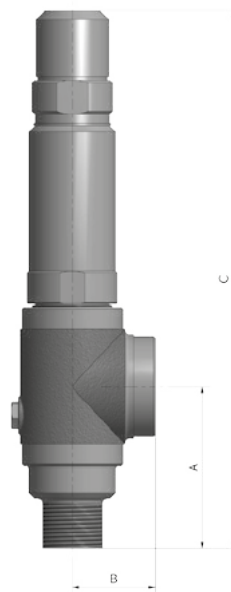

**THREADED
MALE**

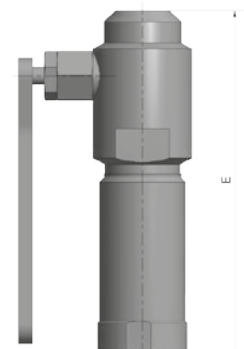

LEVER



■ Correction coefficients charts

If the flow charts on the following pages for the determination of the orifices are used, it will be necessary to apply the correction coefficients indicated here for fluids or working conditions different from those used in the following tables.

CORRECTION FACTORS														
DENS.	Kg	° C	Kt	K	Kc	P1	T (° C)	SUPERHEATED STEAM (° C)						
								0,99	0,97	0,93	0,89	0,85	0,81	0,77
0,20	2,240	-29	1,087	1,01	1,000	0,5	111	136	166	238	299	354,5	417,5	493,5
0,30	1,825	-23	1,075	1,02	1,010	1	119,5	131	170	239	298	353	416,5	493
0,40	1,580	-18	1,063	1,04	1,016	1,5	127	142	174	240	296	351	416	492
0,50	1,414	-12	1,052	1,06	1,022	2	133	146	177	240,5	295	350	414,5	491,8
0,60	1,320	-7	1,041	1,08	1,029	2,5	138	151	179	241	294	349,5	413,5	491,5
0,70	1,195	-1	1,030	1,10	1,033	3	143	156	183	242	293,5	348,5	412	491
0,80	1,117	4	1,020	1,12	1,044	3,5	147	161	185	243	293	347,5	411	491
0,82	1,104	10	1,010	1,14	1,051	4	151	164	188	244	292,5	346,5	410	490,8
0,84	1,091	15	1,000	1,16	1,057	4,5	154,5	168	190	245	292	346	410	490,5
0,86	1,078	21	0,9905	1,18	1,063	5	158	171	193	246	291,5	345	410	490,5
0,88	1,066	27	0,9813	1,20	1,070	6	164	176	198	248	295	344,5	409,5	490,2
0,90	1,055	32	0,9723	1,22	1,076	7	169,5	182	202	251	290,5	344	409	490
0,92	1,043	38	0,9636	1,24	1,083	8	174,5	186	206	253	291	344	408	489,5
0,94	1,031	43	0,9552	1,26	1,089	9	179	191	210	256	292	344,5	407,5	489
0,96	1,021	49	0,9469	1,28	1,095	10	183		214	258	293,5	345,5	407	489
0,98	1,010	54	0,9388	1,30	1,102	11	187		217	261	295,5	346	407	489
1,00	1,000	60	0,9310	1,32	1,108	12	190,5		220	263	298	346,5	407	488,5
1,02	0,990	66	0,9233	1,34	1,113	13	194		224	265	300	347	406,7	488
1,04	0,981	71	0,9158	1,36	1,118	14	197,5		227	267	301,5	348	406,5	488
1,06	0,971	82	0,9014	1,38	1,124	15	200,5		229	268,5	303	349	406	488
1,08	0,962	93	0,8876	1,40	1,130	16	203,5		232	270,5	304,5	350	406	488
1,10	0,953	104	0,8746	1,42	1,136	17	206		234	272	306	351	406	487,8
1,12	0,945	116	0,8619	1,44	1,141	18	209		236	274	307,5	352	406	487,8
1,14	0,937	127	0,8498	1,46	1,146	19	211,5		239	275,5	309	352,5	406,5	487,8
1,16	0,928	138	0,8383	1,48	1,152	20	214		241	277,5	310,5	353	406,7	487,8
1,18	0,921	149	0,8272	1,50	1,157	25	225		251	286	317	359	410	491
1,20	0,913	160	0,8165	1,52	1,162	30	234,5		259	292	323	365,5	415	493
1,25	0,895	171	0,8062	1,54	1,168	35	243		267	298	329	371	420	496
1,30	0,877	182	0,7963	1,56	1,172	40	250,5		274	305	334	377	424	500
1,35	0,861	193	0,7868	1,58	1,177	45	257,5		280	310	340	382	429	503
1,40	0,845	204	0,7776	1,60	1,182	50	264		286	315	346	387	433	506
1,45	0,830	260	0,7360	1,62	1,187	55	270		291	320	351	391	437	510
1,50	0,817	316	0,7005	1,64	1,193	60	275		296	324	355	396	441	512
1,55	0,803	371	0,6695	1,66	1,197	65	281		301	329	360	400	441	515
1,60	0,791	427	0,6425	1,68	1,202	70	286		306	333	364	404	449	518
1,65	0,779	480	0,6183	1,70	1,207									
1,70	0,768	538	0,5968	2,00	1,270									
1,75	0,756			2,20	1,308									
1,80	0,745													
1,90	0,725													
2,00	0,707													
2,10	0,690													
2,20	0,674													
2,30	0,659													
2,40	0,645													
2,50	0,633													



■ Air discharge flow

Medium: Air Capacity in Nm³/h Overpressure: 10%		Air relative density other than 1, multiply by Kg Temperature other than 15 °C, multiply po Kt K values other than 1.01, multiplied by Kc			
P1 (bar g)	Orifices designation / Areas (cm²)				
	C	D	E	F	
	0,31	0,78	1,265	1,98	
0,5	32,5	81,8	132,7	207,7	
1	42,1	106,0	171,9	269,1	
1,5	51,7	130,2	211,1	330,4	
2	61,3	154,3	250,3	391,7	
2,5	71,9	180,9	293,4	459,2	
3	82,5	207,5	336,5	526,7	
3,5	93,0	234,1	379,6	594,1	
4	103,6	260,6	422,7	661,6	
4,5	114,1	287,2	465,8	729,1	
5	124,7	313,8	508,9	796,5	
6	145,8	366,9	595,1	931,5	
7	167,0	420,1	681,3	1066,4	
8	188,1	473,2	767,5	1201,3	
9	209,2	526,4	853,7	1336,3	
10	230,3	579,6	939,9	1471,2	
11	251,5	632,7	1026,1	1606,1	
12	272,6	685,9	1112,3	1741,0	
13	293,7	739,0	1198,5	1876,0	
14	314,8	792,2	1284,7	2010,9	
15	336,0	845,3	1371,0	2145,8	
16	357,1	898,5	1457,2	2280,8	
17	378,2	951,6	1543,4	2415,7	
18	399,3	1004,8	1629,6	2550,6	
19	420,5	1057,9	1715,8	2685,6	
20	441,6	1111,1	1802,0	2820,5	
25	547,2	1376,9	2233,0	3495,2	
30	652,8	1642,7	2664,0	4169,8	
35	758,5	1908,4	3095,1	4844,5	
40	864,1	2174,2	3526,1	5519,1	
45	969,7	2440,0	3957,1	6193,8	
50	1075,4	2705,7	4388,2	6868,4	
55	1181,0	2971,5	4819,2	7543,1	
60	1286,6	3237,3	5250,2	8217,7	
65	1392,2	3503,1	5681,2	8892,4	
70	1497,9	3768,8	6112,3	9567,0	
75	1603,5	4034,6	6543,3	10241,7	
80	1709,1	4300,4	6974,3	10916,4	
85	1814,8	4566,2	7405,4	11591,0	
90	1920,4	4831,9	7836,4	12265,7	
95	2026,0	5097,7	8267,4		
100	2131,6	5363,5	8698,5		
110	2342,9	5895,0	9560,5		
120	2554,1	6426,6	10422,6		
130	2765,4	6958,1	11284,6		
140	2976,7	7489,7	12146,7		
150	3187,9	8021,2	13008,8		
160	3399,2	8552,8	13870,8		
170	3610,4	9084,3	14732,9		
180	3821,7	9615,8			
190	4032,9	10147,4			
200	4244,2				
220	4666,7				
240	5089,2				
260	5511,7				
280	5934,2				
300	6356,7				
320	6779,3				
340	7201,8				
360	7624,3				
380	8046,8				
400	8469,3				
420	8891,8				

■ Steam discharge flow

Medium: STEAM Flow in Kg/h Overpressure: 10%				Values for saturated steam For superheated steam, multiplied by Ks Discharge coefficient = 0.94			
Set press. (bar g)	C	K	Vol.	Orifices designation / Areas (cm ²)			
				C	D	E	F
				0,31	0,78	1,265	1,98
1	0,6698	1,314	0,8804	34,5	86,9	140,9	220,6
1,5	0,6696	1,312	0,7152	42,4	106,7	173,0	270,8
2	0,6693	1,311	0,6034	50,2	126,4	204,9	320,7
2,5	0,6691	1,310	0,5224	58,4	146,8	238,1	372,7
3	0,6689	1,309	0,4610	66,5	167,3	271,3	424,6
3,5	0,6687	1,308	0,4128	74,6	187,7	304,4	476,4
4	0,6686	1,307	0,3739	82,7	208,0	337,3	527,9
4,5	0,6684	1,306	0,3419	90,7	228,2	370,2	579,4
5	0,6683	1,305	0,3150	98,7	248,5	402,9	630,7
6	0,6680	1,303	0,2723	114,8	288,8	468,3	733,0
7	0,6678	1,302	0,2400	130,7	329,0	533,5	835,1
8	0,6675	1,301	0,2146	146,7	369,0	598,5	936,8
9	0,6673	1,300	0,1941	162,6	409,1	663,4	1038,4
10	0,6671	1,299	0,1773	178,5	449,0	728,2	1139,8
11	0,6669	1,298	0,1631	194,3	488,9	792,9	1241,1
12	0,6668	1,297	0,1511	210,2	528,8	857,6	1342,4
13	0,6666	1,296	0,1407	226,0	568,7	922,3	1443,6
14	0,6665	1,295	0,1316	241,8	608,5	986,9	1544,7
15	0,6663	1,294	0,1236	257,7	648,4	1051,5	1645,8
16	0,6662	1,293	0,1166	273,5	688,2	1116,1	1747,0
17	0,6661	1,293	0,1103	289,4	728,1	1180,8	1848,1
18	0,6660	1,292	0,1046	305,2	767,9	1245,4	1949,3
19	0,6659	1,292	0,0995	321,1	807,8	1310,1	2050,6
20	0,6658	1,291	0,0949	336,9	847,7	1374,8	2151,9
25	0,6653	1,289	0,0769	416,4	1047,8	1699,2	2659,7
30	0,6651	1,287	0,0645	496,4	1248,9	2025,5	3170,4
35	0,6650	1,287	0,0554	576,9	1451,6	2354,3	3684,9
40	0,6650	1,287	0,0485	658,2	1656,2	2686,0	4204,2
45	0,6651	1,287	0,0430	740,4	1862,9	3021,3	4729,0
50	0,6654	1,289	0,0386	823,5	2072,1	3360,6	5260,0
55	0,6659	1,292	0,0349	907,8	2284,1	3704,4	5798,2
60	0,6665	1,295	0,0319	993,3	2499,3	4053,4	6344,4
65	0,6673	1,300	0,0292	1080,2	2718,0	4408,0	6899,5
70	0,6683	1,305	0,0269	1168,7	2940,5	4768,9	7464,4
75	0,6695	1,312	0,0249	1258,8	3167,4	5136,8	8040,3
80	0,6709	1,320	0,0232	1350,9	3399,0	5512,5	8628,3
85	0,6725	1,329	0,0216	1445,0	3635,9	5896,6	9229,5
90	0,6744	1,340	0,0202	1541,5	3878,5	6290,2	9845,5
95	0,6765	1,352	0,0189	1640,5	4127,6	6694,1	10477,7
100	0,6790	1,366	0,0178	1742,2	4383,7	7109,4	11127,8
110	0,6848	1,401	0,0158	1955,4	4920,1	7979,4	12489,5
120	0,6920	1,445	0,0141	2183,9	5494,9	8911,6	13948,6
130	0,7010	1,501	0,0126	2431,2	6117,3	9921,0	15528,5
140	0,7121	1,574	0,0114	2702,5	6799,8	11027,8	17260,9
150	0,7258	1,670	0,0102	3004,4	7559,4	12259,9	19189,3
160	0,7431	1,798	0,0092	3346,9	8421,3	13657,7	21377,2
170	0,7651	1,975	0,0082	3753,2	9443,7	15315,7	23972,4
180	0,7940	2,236	0,0074	4225,3	10631,4	17241,9	26987,3
190	0,8339	2,653	0,0066	4833,4	12161,4	19723,3	30871,3
200	0,8957	3,457	0,0058	5685,6	14305,6	23200,8	36314,3
210	1,0154	5,773	0,0049	7160,4	18016,6	29219,2	45734,4



■ Liquids discharge flow

Set press. Bar g	Orifices designation / Areas (cm ²)			
	C	D	E	F
	0,31	0,78	1,265	1,985
1	1,38	3,48	5,64	8,86
2	1,87	4,71	7,64	11,99
3	2,29	5,77	9,36	14,69
4	2,65	6,66	10,81	16,96
5	2,96	7,45	12,08	18,96
6	3,24	8,16	13,24	20,77
7	3,50	8,82	14,30	22,44
8	3,75	9,42	15,28	23,98
9	3,97	10,00	16,21	25,44
10	4,19	10,54	17,09	26,82
11	4,39	11,05	17,92	28,12
12	4,59	11,54	18,72	29,37
13	4,77	12,01	19,48	30,57
14	4,96	12,47	20,22	31,73
15	5,13	12,91	20,93	32,84
16	5,30	13,33	21,62	33,92
17	5,46	13,74	22,28	34,96
18	5,62	14,14	22,93	35,98
19	5,77	14,52	23,56	36,96
20	5,92	14,90	24,17	37,92
21	6,07	15,27	24,76	38,86
22	6,21	15,63	25,35	39,77
23	6,35	15,98	25,92	40,67
24	6,49	16,32	26,47	41,54
25	6,62	16,66	27,02	42,40
26	6,75	16,99	27,56	43,24
27	6,88	17,31	28,08	44,06
28	7,01	17,63	28,60	44,87
29	7,13	17,94	29,10	45,67
30	7,25	18,25	29,60	46,45
31	7,37	18,55	30,09	47,21
32	7,49	18,85	30,57	47,97
33	7,61	19,14	31,04	48,71
34	7,72	19,43	31,51	49,45
35	7,83	19,71	31,97	50,17
36	7,95	19,99	32,42	50,88
37	8,06	20,27	32,87	51,58
38	8,16	20,54	33,31	52,27
39	8,27	20,81	33,75	52,96
40	8,38	21,07	34,18	53,63
45	8,88	22,35	36,25	56,88
50	9,36	23,56	38,21	59,96
55	9,82	24,71	40,08	62,89
60	10,26	25,81	41,86	65,68
65	10,68	26,86	43,57	68,37
70	11,08	27,88	45,21	70,95
75	11,47	28,86	46,80	73,44
80	11,84	29,80	48,33	75,85
85	12,21	30,72	49,82	78,18
90	12,56	31,61	51,27	80,45
95	12,91	32,48	52,67	
100	13,24	33,32	54,04	
110	13,89	34,95	56,68	
120	14,51	36,50	59,20	
130	15,10	37,99	61,62	
140	15,67	39,43	63,94	
150	16,22	40,81	66,19	
160	16,75	42,15	68,36	
170	17,27	43,45	70,46	
180	17,77	44,71		
190	18,25	45,93		

■ DEFINITIONS (EN ISO 4126-1)

Blowdown: The difference between the set and re-seating pressures, normally stated as a percentage on the set pressure of a safety valve except for pressures of less than 3 bar when it is expressed to operate.

Built-up back pressure: The pressure existing at the outlet of the safety valve caused by flow through the valve and the discharge system.

Coefficient of discharge: The value of actual flowing capacity (from tests).

Cold differential test pressure: The inlet static pressure at which a safety valve is set to initiate to open on the test bench. This test pressure includes corrections for service conditions, as back pressure and/or temperature.

Flow area: The minimum cross-sectional flow area (but not the curtain area) between inlet and nozzle which is used to calculate the theoretical flow to discharge.

Flow diameter: The diameter corresponding to the flow area.

Lift: The actual travel of the valve disc starting from the closed position.

Maximum allowable pressure: The maximum pressure for which the equipment is designed as specified by the manufacturer.

Overpressure: A pressure increase over the set pressure, at which the safety valve achieves the lift specified by the manufacturer, usually expressed as a percentage of the set pressure.

Pressure: The pressure unit used in this standard is the bar (1 bar = 10^5 Pa). It is quoted as gauge (relative to atmospheric pressure) or absolute as appropriate.

Relieving pressure: The pressure used for the sizing of the safety valve which is greater than or equal to the set pressure plus the overpressure.

Re-seating pressure: The value of the inlet static pressure at which the disc re-establishes contact with the seat or at which the lift becomes zero.

Safety valve: Valve which automatically, without the assistance of any energy other than that of the fluid concerned, discharges a quantity of the fluid so as to prevent a predetermined safe pressure being exceeded and which is designed to re-close and prevent further flow or fluid after nominal pressure conditions of service have been restored.

Set pressure: The predetermined pressure at which a safety valve under operating conditions initiates to open.

Superimposed back pressure: The pressure existing at the outlet of the safety valve at the time when the device is required to operate.



C/ Compositor Vivaldi, 2 - 8 - Pol. Ind Can Jardí
08191 Rubí (Barcelona) Spain
Tel.: +34 936 995 200
safety@valvulasnacional.com
www.valvulasnacional.com

Member of Pekos group



Authorized Partner
by Nacional Safety Valves

www.valpro.com.tr